

## THREE-PHASE TWO-SWITCH SINGLE INDUCTOR ZVS PFC BOOST RECTIFIER

T.Sivackani<sup>1</sup> and J.Prasanth Ram<sup>2</sup>

<sup>1</sup>Final ME(PED) ,Department of Electrical and Electronic Engineering, Sri Shakthi Institute of Engineering and Technology, Coimbatore-641062

<sup>2</sup>Assi Prof, Department of Electrical and Electronic Engineering, Sri Shakthi Institute of Engineering and Technology, Coimbatore-641062

### ABSTRACT

This paper deals with AC to DC converter with ZVS and PFC. This circuit make input voltage and input current of the rectifier or power consuming in phase and so this circuit is called as unity power factor rectifier. A single inductor is used to boost the voltage. The output THD also reduced. The load can be changed as motor load. The motor may be either wiper motor or high voltage dc motor.

**KEYWORDS:** ZVS(Zero Voltage switching), PFC(Power Factor Correction)

### I. INTRODUCTION

The simplicity and low cost of single and two - switch rectifiers are so attractive. They are increasingly employed in cost sensitive applications like three – phase battery chargers. Another major concern in the application of three phase boost topology is the high output voltage on the low cost and performance of downstream converters. In this paper a new three-phase, two-switch, zero-voltage switching (ZVS), discontinuous-current-mode (DCM), PFC boost rectifier with single boost Inductor was introduced. The voltage of the rectifier is boost up to triple the input voltage. The PF is achieved nearly unity. The R load is used by connecting a resistor with the rectifier back end.

### II. BOOST RECTIFIER

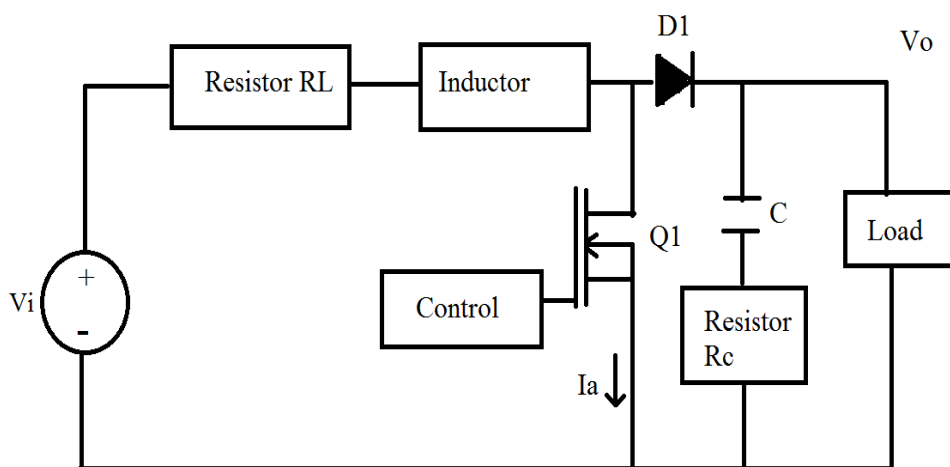

Figure 1. Boost Rectifier

To boost the voltage an inductor was used to store the energy in magnetic field and deliver the energy to the load. To reduce the ripple current a capacitor was used in parallel with the load. In this paper a single boost inductor was used in the output of the diode bridge rectifier.

**2.1. AC Input Side Boost Inductor**

In paper [10] a Taipei rectifier with three boost inductors were used in AC side. Each inductors  $L_1, L_2$  and  $L_3$  of approximately  $200\mu\text{H}$  and filter capacitors  $C_1, C_2,$  and  $C_3$  which carry the ac component of the boost-inductor currents and triplen harmonic  $C_R$  a flying capacitor were used in DC output side of the rectifier. The three capacitors are connected in parallel with each phase of AC input to form a virtual neutral. Virtual neutral is explained in paper[10].

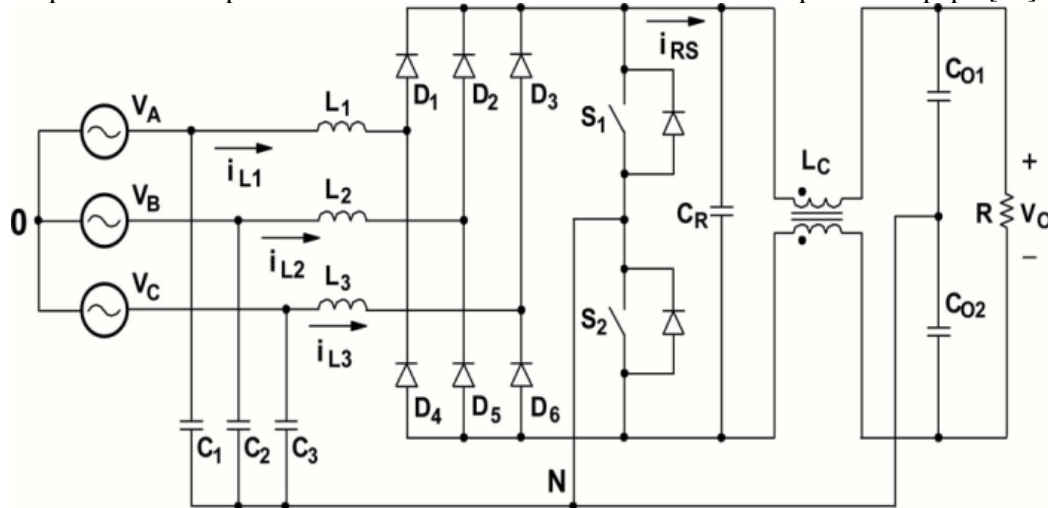

Figure 2. Taipei Rectifier with three Inductors

**2.2. DC Output side single boost inductor**

In this paper three single-phase AC input voltage or a three-phase AC voltage source are taken as the input of the rectifier. This three-phase supply connected to a diode bridge rectifier. Six diodes were connected in bridge configuration.

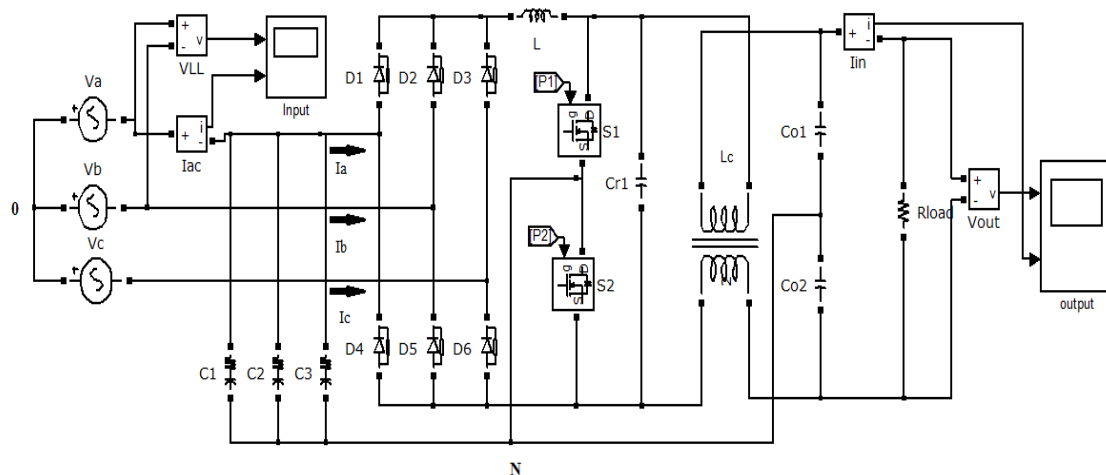

Figure 3. Three-phase rectifier with single boost inductor

The diodes  $D_1, D_3, D_5$  were conduct during the positive half cycle of the AC supply. The diodes  $D_2, D_4, D_6$  were conduct during negative half cycle of the AC supply.

Three capacitors were connected in star connection in the three-phase input AC lines. These three capacitors form the virtual neutral [10] for the whole circuit .The midpoint of the two series connected switches were connected with this neutral point.  $V_{LL}$  is the AC line to line voltage.  $I_a, I_b, I_c$  were the three-phase AC input current. Two MOSFET switches were connected in the output of the rectifier.

The switches were triggered during zero crossing of each phase voltages.  $C_R$  is a flying capacitor used to filter the triplen harmonics. A coupled inductor is used to isolate the load voltage and the switches. If the switches connected directly to the load the switching frequencies of the MOSFET affect the output supply.

Two capacitors were connected parallel with each other and to the coupled inductor. The midpoint of these two capacitors were connected to the virtual neutral. Due to the split capacitors the output load voltage is split equally by the connection of virtual neutral. This sharing between capacitors will reduce the ripples in the load supply.

### 2.3. Input Supply

Three-phase input were given as  $V_a$ ,  $V_b$ ,  $V_c$ .

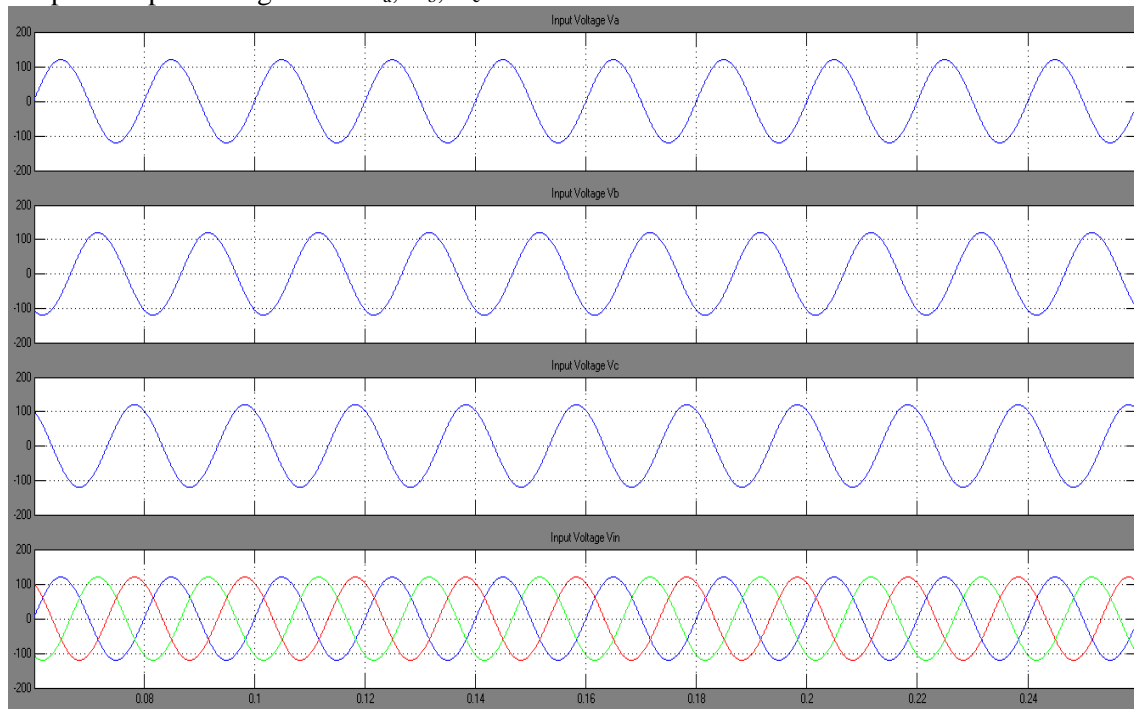

Figure 4 Input Voltage

### 2.4. R Load

In this paper a resistive load is used. R load of  $217 \Omega$  were used. The waveform for R load is shown here. The load voltage is maintained as constant voltage by PI controller. Reference voltage is given to the PI controller and the output voltage is feedback to the PI controller. The controller compare two voltages and give an error voltage which is used as reference signal to an comparator. This wave was compared with triangular waves and generate square pulses for the two MOSFET switches. It should be noted in the circuit of Figure 5 that if a pure resistive is connected as load, the input current follows the waveform of input voltage. The voltage waveforms are shown in Figure 4. The circuit will have power factor equals to unity but a large output voltage ripple. It is comprised of a diode-bridge rectifier followed by a large-input-filter capacitor. This input-filter capacitor reduces the ripple on the voltage waveforms into the DC converter stage. The problem with this input circuit is that it produces excessive peak input currents and high harmonic distortion on the line. The high distortion in the input current occurs due to the fact that the diode rectifiers only conduct during a short interval. This interval corresponds to the time when the mains instantaneous voltage is greater than the capacitor voltage. Since the capacitor must meet hold-up time requirements, its time constant is much greater than the frequency of the mains. The DC output voltage of rectifier should be as ripple free as possible. Therefore, a large capacitor is connected as a filter on the DC side. The capacitor will be charged during the peak of the AC input voltage and this will result in high peak input current. This rectifier draws highly distorted current from the utility.

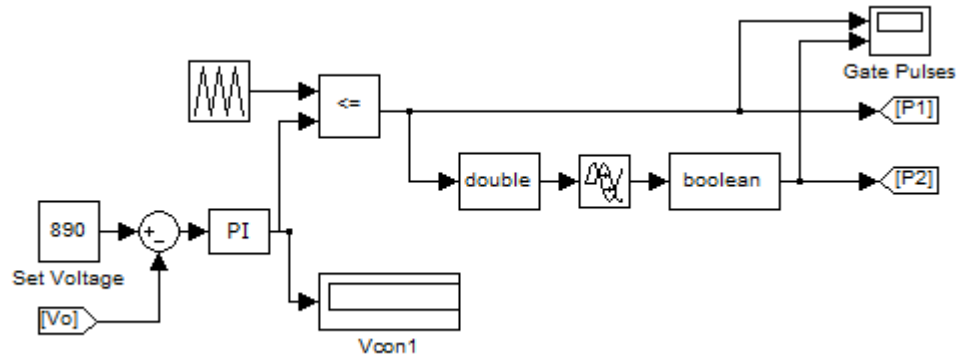

Figure 5 PI controller with set voltage

The mains instantaneous voltage is greater than the capacitor voltage only for very short periods of time, during which, the capacitor must be charged fully. Therefore, large pulses of current are drawn from the line over a very short period of time. Therefore, the generation of harmonic currents due to the behaviour of Three-phase rectifiers, distorted currents are normally drawn from the input line resulting in low power factor, low distortion factor and high total harmonic distortion.

They draw high amplitude current pulses, the fundamental current of the line current is essentially in phase with the voltage, and the displacement factor is close to the unity. However, the low-order current harmonics are quite large, close to that of the fundamental. From the line current spectrum it must be contains a lowered fundamental frequency component plus 3rd, 5th, 7th, 9th and higher of current harmonics.

### III. OPERATION OF THE BOOST RECTIFIER

During positive half cycle switch S1 is ON the Dc flows through the boost inductor. The inductor will store the energy during this period. When the switch is turned OFF the stored energy will flow through  $C_R$  and to the load. When switch S2 is turned on the DC current will again flow through the boost inductor again energy will be stored. If S2 is turned OFF the stored energy will flow towards the capacitor  $C_R$  and to the load.

There will be a delay period between the turn OFF of S1 and turn ON of switch S2. This period will be minimum. So it is ignored one and during this period only the inductor will be discharging the energy to the load.

The inductor L1 65e-6H input AC Line to Line voltage 120V, capacitors C1, C2, C3 are approximately 2.2e-6 F, capacitors C01, C02 are 270e-6F, R Load 217Ω.

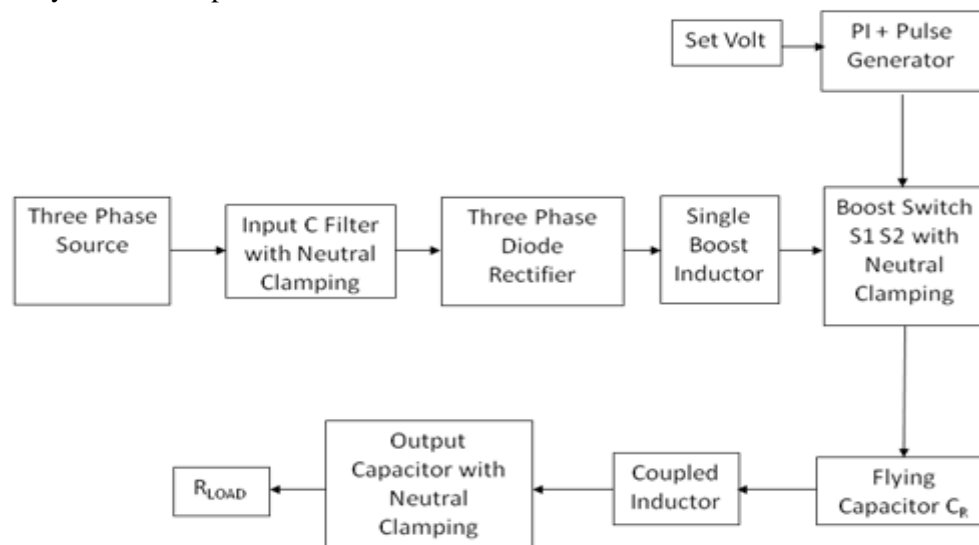

Figure 6 Block diagram of Boost rectifier

### 3.1. MOSFET switching voltage and current

The switching waveforms for the two switches are shown here.

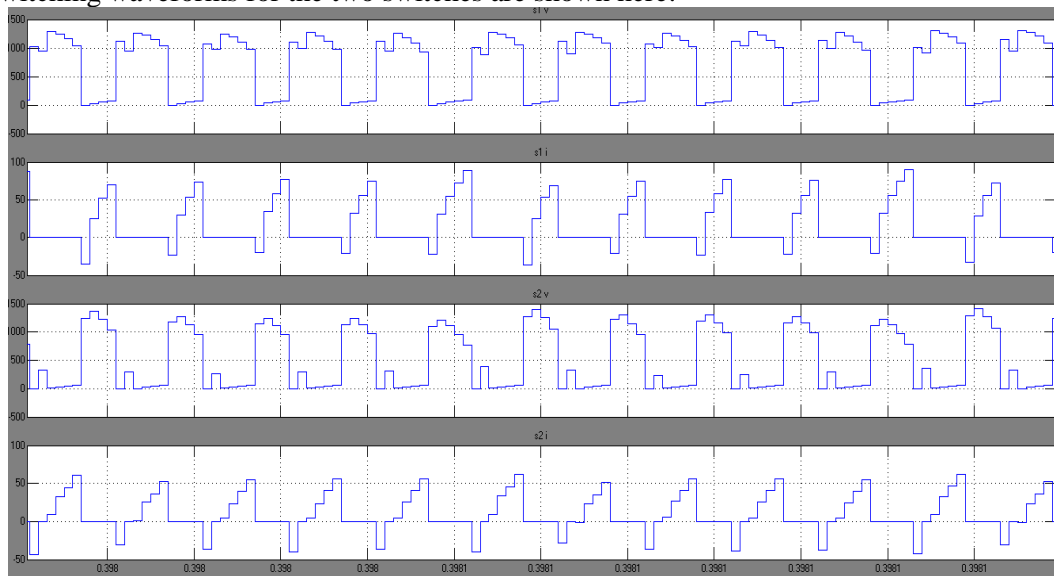

Figure 7 S1, S2 Voltage and Current waveform

### 3.2. THD, PF and Efficiency at 100, 75, 50 and 25% Load

Table 1.

Output Power[W]	THD[%]	PF[%]	Efficiency[%]
2765	2.80	0.9929	98.16
2110	4.20	0.9919	98.00
1410	3.71	0.9889	97.54
700	4.78	0.9240	93.99

### 3.3. Output

The input voltage for each single phase AC voltage is 300V and 50HZ frequency. The output DC voltage is about 890V. The output current is 4A. The harmonics were reduced by the split capacitors.

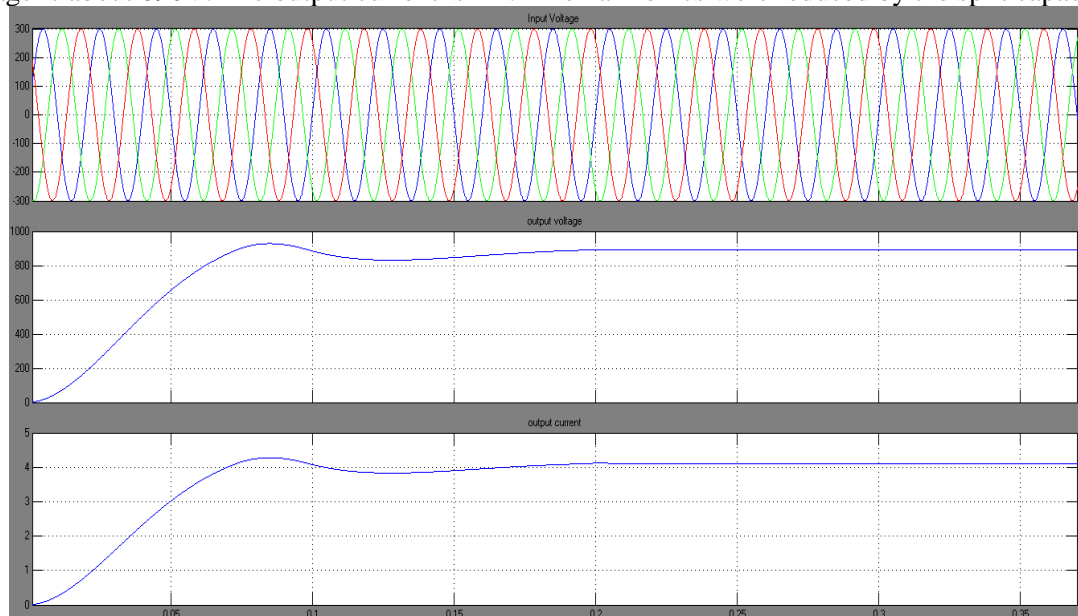

Figure 8 Output current and voltage

## IV. CONCLUSIONS

Rectifier is used to convert AC voltage to DC voltage. Using this project not only converting three-phase AC to DC voltage but also getting high voltage nearly 900V and the current is 4.1A. In [10] three boost inductors are used for boost the voltage. In this paper single boost inductor is used in the DC output side of the rectifier. The input and output voltages were balanced by virtual neutral. So the Power Factor is nearly unity.

## REFERENCES

- [1] A.R.Prasad, P.D.Ziogas, and S.Manias, "An active powerfactor correction technique for three-phase diode rectifiers," in *Proc.IEEE Power Electron. Specialist' Conf.(PESC)Rec.* Jun.1989,vol.1,pp.58-66.
- [2] S.Gatari' c,D.Boroyevich, and F.C.Lee,"Soft-Switched single-switch three-phase rectifier with power factor correction,"in *Proc.IEEE Appl.Power Electron. Conf.(APEC)* ,Feb.1994,vol.2,pp.738-744.
- [3] Q.Huang and F.C.Lee, "Harmonic reduction in a single-switch, three-phase boost rectifier with high order harmonic injected PWM," in *IEEE Power Electron Specialists' Conf.(PECS)Rec*, Jun.1996,vol.2,pp.1266-1271
- [4] J.Sun, N.Frohleke, and H.Grotstollen,"Harmonic reduction techniques for single-switch three-phase boost rectifiers,"in *Proc.IEEE LAS Annu Meet.Rec.* 'Oct.1996,vol.2,pp.1225-1232.
- [5] Y.Jang and M.M.Jovanovi c, "A novel, robust, harmonic injection method for single-switch three-phase, discontinuous-conduction-mode boost rectifiers," *IEEE Trans. Power Electron* , vol.13,no.5,pp.824-834,Sep.1998.
- [6] D.M..Xu,C.Yang, J.H.Kong and Z.Qian,"Quasi soft-switching partially decoupled three-phase PFC with approximate power factor," in *Proc. IEEEc Appl. Power Electron. Conf.(APEC)* ,Feb.1998,vol.2,pp.953-957
- [7] P.Barboss, F.Canales, F.C.Lee, "Analysis and evaluation of the two-switch three-level boost rectifier,"in *Proc. IEEEc Appl. Power Electron Specialists' Conf.(PESC)Record, 2001*, vol.3,pp.1659-1664.
- [8] K.Nishimura,K.Hirachi, A.M.Edi,H.W.Lee,and N.Nakaoka, "A novel prototype discontinuous inductor current mode operated three-phase PFC power Converter with four active switches," in *Proc. IEEEc Appl. Power Electron specialist' Conf.(PECS)Record* , Jun.2006,pp.824-830.
- [9] J.W.Kolar and T.Friedli, "The essence of three-phase PFC rectifier systems," in *Proc. IEEE Int. Telecommon Energy Conf, Rec.* ,2011,Plenary Session 2,Paper 12.1.
- [10] Yungtaek Jang , senior Member ,IEEE, and Milan M.Jovanovi' c,Fellow, IEEE, "The TAIEI Rectifier-A New Three-Phase Two-Switch ZVS PFC DCM Boost Rectifier," *IEEE transaction s on power electronics*, vol.28,no.2.february2013

## AUTHORS

**T Sivackani** final ME(PED) in Sri Shakthi Institute of Engineering and Technology.



**J.Prasanth Ram** AP/EEE in Sri Shakthi Institute of Engineering and Technology.